

Grease Pump

Rail Grease Pump - FP-112-GP

Features

- Mounts to a 20L grease bucket
- 4 stroke recoil start petrol engine
- Tare weight < 21.5 kg
- 3.8 L/min pumping capacity
- Includes clutch and pressure cut off
- Includes carry handle and support leg
- Fully guarded

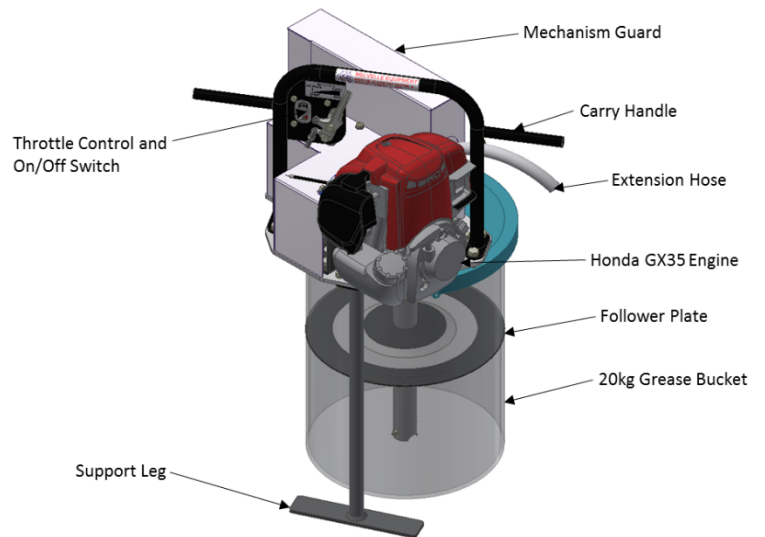

Lid locking points

